

## Rotary cutting

### Setting fabric (fig. 7)

1. Cut a strip  $14\frac{1}{2}$ " x 40" (or width of fabric). From this strip, cut one  $13\frac{1}{4}$ " square and one  $13\frac{1}{4}$ " x  $6\frac{7}{8}$ " rectangle. From the remainder of this strip, cut four  $7\frac{1}{4}$ " squares.
2. Cut three strips  $7\frac{1}{4}$ " x 40". Cut fourteen  $7\frac{1}{4}$ " squares from these strips.
3. Cut the eighteen  $7\frac{1}{4}$ " squares in half diagonally to make 36 half-square-triangles.

### Inner border

Cut your black and white scraps into strips  $1\frac{1}{2}$ " wide.

### Outer border

Cut four lengthwise strips of fabric,  $9\frac{1}{2}$ " wide each.

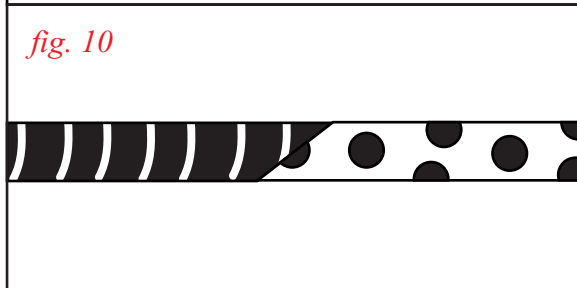
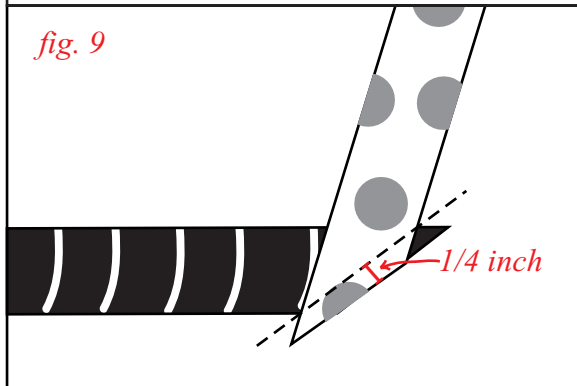
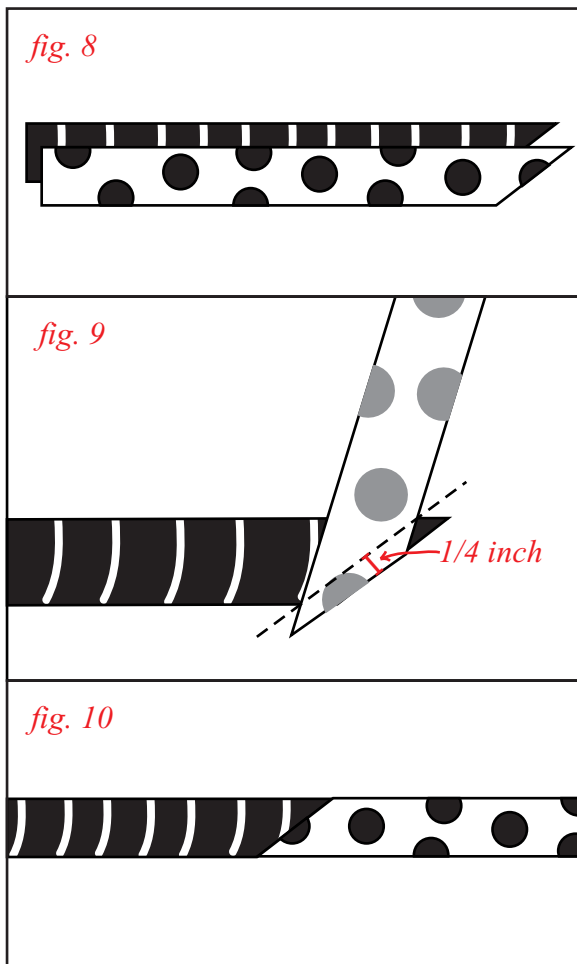
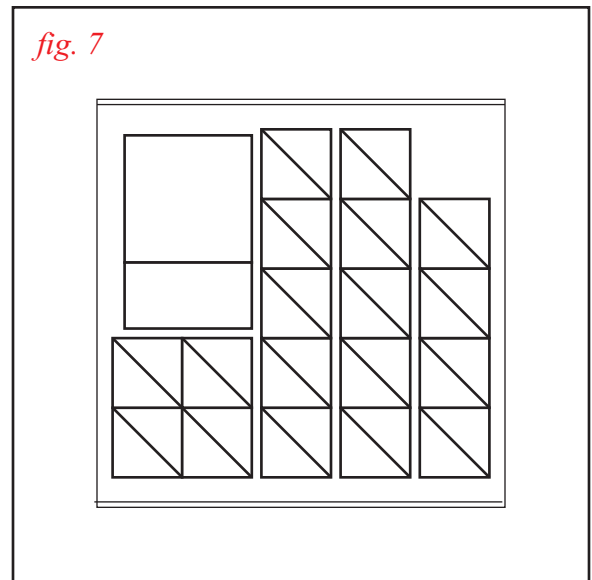

## Piecing

### Setting the blocks

1. Set the eight whole blocks on point by sewing a half-square-triangle to each side of the blocks. Sew two half-square-triangles to each half block to make rectangles.
2. Arrange and sew the blocks, half blocks, and background spacers into three vertical rows and sew rows together.

### Inner border

1. Stack the first two strips on top of each other, both sides facing up. Using your rotary cutter and ruler, cut an angle on one end; It does not have to be 45 degrees. (fig. 8)
2. Flip one strip over so right sides are facing and the angled edges are lined up. Slide the top strip back and forth until you have a  $\frac{1}{4}$ -inch seam allowance when you sew from one intersection to the next. (fig. 9)
3. Flip the top strip back over and press. (fig. 10)
4. Continue to add pieces to this strip in the same manner until it is long enough for one side of the quilt. Make three more pieced strips for the remaining sides.
5. Measure the length from top to bottom through the center of the quilt; it should be about  $45\frac{1}{8}$ ". Trim two of your pieced inner borders to match your measurement and sew them to the sides of the quilt.
6. Measure the width from side to side through the center of the quilt; it should be about  $40\frac{3}{4}$ ". Trim the remaining two pieced inner borders to match your measurement and sew them to the top and bottom of the quilt.

### Outer border

1. Measure the length from top to bottom through the center of the quilt; it should be about  $47\frac{1}{8}$ ". Cut two of your outer border strips to match your measurement and sew them to the sides of the quilt.
2. Measure the width from side to side through the center of the quilt; it should be about  $59\frac{1}{4}$ ". Cut the remaining two border strips to match your measurement and sew them to the top and bottom of the quilt. ☺